

Link 1000

Owner's Guide

xantrex[™]
Smart choice for power

About Xantrex

Xantrex Technology develops, manufactures, and markets advanced power electronic products. The company's products convert raw electrical power from any source into high-quality power required by electronic and electrical equipment.

Trademark

Xantrex is a registered trademark of Xantrex International

Other trademarks, registered trademarks, and product names are the property of their respective owners and are used herein for identification purposes only.

Notice of Copyright

Link 1000 Owner's Guide © July 2003 Xantrex International. All rights reserved.

Disclaimer

UNLESS SPECIFICALLY AGREED TO IN WRITING, XANTREX TECHNOLOGY INC. ("XANTREX")

(a) MAKES NO WARRANTY AS TO THE ACCURACY, SUFFICIENCY OR SUITABILITY OF ANY TECHNICAL OR OTHER INFORMATION PROVIDED IN ITS MANUALS OR OTHER DOCUMENTATION.

(b) ASSUMES NO RESPONSIBILITY OR LIABILITY FOR LOSS OR DAMAGE, WHETHER DIRECT, INDIRECT, CONSEQUENTIAL OR INCIDENTAL, WHICH MIGHT ARISE OUT OF THE USE OF SUCH INFORMATION. THE USE OF ANY SUCH INFORMATION WILL BE ENTIRELY AT THE USER'S RISK.

Date and Revision

July 2003, Revision A

Part Number

975-0056-01-01

Contact Information

Web: www.xantrex.com

Email: CustomerSupport@xantrex.com

Phone: 1-800-670-0707 (toll free in North America) 1-604-422-2777 (direct)

Fax: 1-604-420-2145

Contents

1 Introducing Link 1000

Introducing the Link 1000- - - - -	2
Inverter/Charger Control Functions - - - - -	2
Monitoring Functions - - - - -	2
Reading the Link 1000 Control Panel - - - - -	4
Where to go From Here - - - - -	6

2 Installing the Link 1000

Planning the Installation - - - - -	8
Supplied Parts - - - - -	8
Materials You Need to Supply - - - - -	8
Tools - - - - -	9
Installation Considerations - - - - -	9
Safety - - - - -	9
Performance - - - - -	9
Color-Coded Wiring - - - - -	10
Twisted Pair Wires - - - - -	10
Separate Engine Starting Battery - - - - -	10
Installing the Link 1000 - - - - -	11
Overview of Installation Steps - - - - -	11
Mounting the Link 1000 Control Panel - - - - -	13
Mounting and Cabling the Shunt - - - - -	14
Wiring the Terminal Block - - - - -	15
Connecting Terminal Block Wires to Shunt and Battery - - - - -	16
Installing Fuses - - - - -	17
Connecting the Phone Cable - - - - -	17
Testing the Installation - - - - -	17

Maintenance----- 18
Disconnecting the Inverter/Charger ----- 18

3 Setting up the Link 1000

About Link 1000 Settings ----- 20
 Probable Changes ----- 20
 Possible Changes ----- 20
 Other Settings ----- 20
 How to Enter Setup Mode and Change a Value ----- 20
Locking Your Setup Values ----- 21
Resetting Values ----- 21
Battery Capacity ----- 22
 Estimated Capacities for 12 Volt Flooded Batteries ----- 22
 Estimated Capacities for Gel Cell Batteries ----- 22
 Estimated Capacities for Multiple Batteries ----- 22
 Changing the Battery Capacity Setting ----- 23
 Changing the Battery Type Setting ----- 23
 Changing the Ambient Temperature Setting ----- 24
Charged Parameters----- 25
 Changing the Charged Voltage Setting ----- 25
 Changing the Charged Current Percentage Setting ----- 25
 Changing the Time Remaining Setting ----- 26
 Changing the Power Share Setting ----- 27
 Changing the Idle Mode Setting ----- 28
Advanced Function Values----- 29
 How to Enter Setup Mode and Change a Value: Reminder -- 29
 F01 Auto Display Scanning ----- 29
 F02 Display Sleep ----- 29
 F03 Set or Display Ambient Battery Temperatures ----- 30
 F04 Toggle Display Between Ah and kWhr ----- 30
 F05 Turn on Alternative Energy Mode ----- 31
 F06 Manually Set CEF ----- 31
 F07 Set Temperature Coefficient ----- 31
 F08 Set Peukert’s Exponent ----- 32
 F09 Set Low Battery Discharge Floor ----- 32

F10 Select Battery Type	33
F11 Turn on Second Battery Voltage Sense	33
F12 Number of Overload Conditions Experienced	33
F13 Number of Inverter Low Battery Shutdowns	33
F14 Test Control Panel Display	34
F15 Display Software Revision Number	34
F16 Turn on Active Temperature Compensation	34

4 Using the Link 1000

Monitoring Functions	36
Choosing a Display Unit: Volts, Amps, Ah, or Time	36
Reading the Battery State-of-Charge	37
Scaling the BATTERY STATUS Light Bar	37
Inverter Functions	38
Turning on the Invert Function	38
Changing the Idle Mode Setting	38
Charging Functions	39
Summary of CHARGER STATUS LEDs	39
Charging the Batteries	40
Equalizing the Batteries	40
Precautions	40
Equalizing Gel Cell Batteries	42
Activating Power Share	42
Battery Capacity Testing	42
Synchronizing the Link 1000 to the Battery	44
Over-charge Ah (Accumulation of Positive Ah)	45
Battery History	46
Interpreting Battery History	46
Reading Error Codes	48

A Specifications

Control Panel: Electrical Specifications- - - - - 52
Control Panel: Physical Specifications - - - - - 52
Default Settings- - - - - 53

B Product and System Information

Warranty - - - - - 56
Disclaimer - - - - - 58
 Product - - - - - 58
 Exclusions - - - - - 58
 Warning: Limitations On Use - - - - - 59
Return Material Authorization Policy - - - - - 59
Return Material Procedure - - - - - 59
Product Information - - - - - 60
Record of System Settings - - - - - 61

Index - - - - - 63

Figures

Link 1000 Control Panel	4
System Overview (Wiring)	12
Display Panel and Mounting Plate	13
Link 1000 Mounting Plate	14
BATTERY STATUS Light Bar	37

1

Introducing Link 1000

Chapter 1 describes:

- The Link 1000's control and monitoring functions
- The features on its control panel

Introducing the Link 1000

The Link 1000 gives you complete remote control of the Freedom 458, Freedom, and Freedom Marine Inverter/Chargers. It also lets you monitor the performance of your battery power system.

Inverter/Charger Control Functions

From the Link 1000 control panel, you can:

- Turn the invert function on and off
- Start or end an equalization cycle
- Activate the Power Share feature. This automatically lowers the charger's output to prevent AC breakers from tripping if too many loads come on at once.
- Place the inverter/charger in Idle (standby) mode so it only begins inverting at a level that you choose. This power-saving feature minimizes the draw on your battery by turning the inverter off until it's really needed.
- Make custom settings for numerous functions including battery type, battery capacity, and Power Share mode. These let you set up the Link 1000 so it suits the characteristics of your system.
- Lock your setup values so no one can inadvertently change them

Monitoring Functions

The Link 1000 control panel lets you see:

- The battery's state-of-charge at a glance
- The voltage of the battery being monitored and the voltage of a second (starting) battery
- The flow of current into the battery (charge rate)
- The flow of current out of the battery (consumption rate)
- The number of Ah (Amp-hours) that have been consumed

- The time remaining in your battery before it is completely discharged
- Which charging stage the batteries are in (Bulk, Acceptance, Float, or Equalization)
- Battery history including:
 - Present charge efficiency
 - The number of deep cycles the battery has had
 - The deepest level of discharge
 - The average level of discharge

Reading the Link 1000 Control Panel

The Link 1000 control panel lets you monitor the battery system and control the inverter/charger. Its features are described below. Further details are provided as you need them throughout the guide.

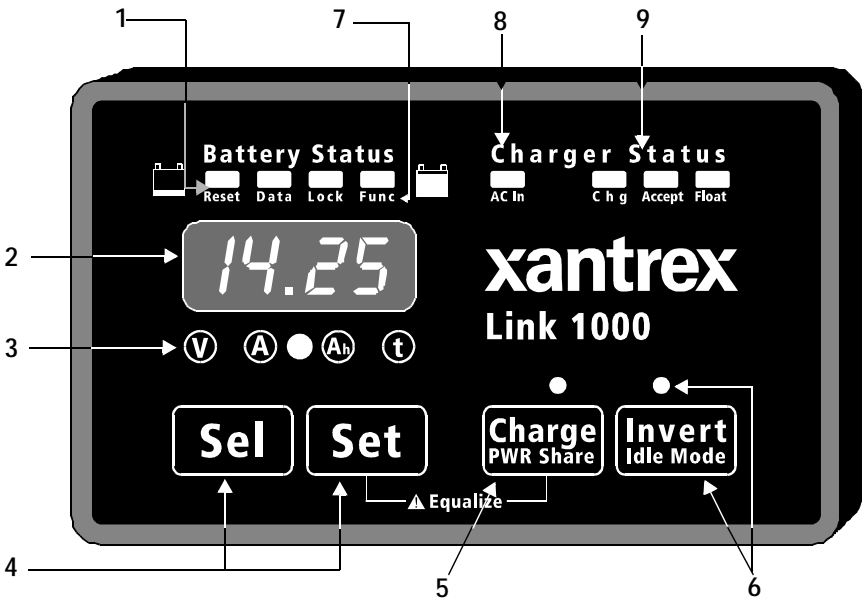





Figure 1 Link 1000 Control Panel

- 1** **BATTERY STATUS** light bar
When the battery system is operating, the four LEDs in this light bar act like a “fuel gauge”. The LEDs light in different sequences and colors to show the battery’s present state-of-charge. The statuses are described on [page 37](#).

- 2, 3 **Numeric display and display units.**
You can choose from four display units depending on the type of information you want to see:
- Volts 
 - Amps 
 - Ah (Amp-hours) 
 - Time Remaining 
- The procedure for changing display units is given on [page 36](#) along with an explanation of each display unit.
Note: The numeric display also shows Error Codes. If an error occurs, the display alternates between the monitoring function you have selected and the Error Code. For details about Error Codes, see [page 48](#).
- 4 **SEL and SET buttons**
SET lets you access Setup mode and advanced functions. Once you are in Setup mode, you press **SEL** to choose a function or a setting. Procedures for changing values are given in [Chapter 3](#).
- 5 **CHARGE/PWR SHARE button and LED**
Lets you start a charge cycle (see [page 40](#)) or change the Power Share mode setting (see [page 27](#)).
- 6 **INVERT/IDLE MODE button and LED**
Lets you activate the invert function (see [page 38](#)) or change the Idle mode setting (see [page 28](#)).
- 7 **RESET, DATA, LOCK, FUNC LEDs**
- **RESET:** When it is on, this LED indicates that you are resetting Ah (Amp-hours) to zero or that you are returning all settings to the factory defaults. (See [page 21](#).)
 - **DATA:** Indicates that you are looking at historical information about your batteries. (See [“Interpreting Battery History” on page 46](#).)
 - **LOCK:** Indicates you are choosing the setting that prevents people from inadvertently changing your setup values. (See [page 21](#).)
 - **FUNC:** Indicates you are accessing the advanced functions. (See [“Advanced Function Values” on page 29](#).)

- 8 **AC IN LED**
Indicates that AC power is present.
- 9 **CHARGER STATUS LEDs:**
- **CHG** (Red): When this LED is on solid, the battery is in Bulk charge mode. When this LED is flashing, the battery is equalizing.
 - **ACCEPT** (orange): The battery is in Acceptance mode.
 - **FLOAT** (green): The battery is in Float mode.

Where to go From Here

- To install the Link 1000, see [page 7](#).
- To set up the Link 1000, see [page 19](#).
- To use the Link 1000, see [page 35](#).
- To call for technical support, see [page 56](#).

2

Installing the Link 1000

Chapter 2 gives:

- An overview of the installation process
- A list of installation tools and equipment
- Installation procedures

We recommend that you read the entire chapter so you can plan the installation and obtain all the materials you need before starting the installation.

Planning the Installation

Supplied Parts

- Link 1000 control panel and 4 mounting screws
- 500 amp precision shunt
- 25 foot RJ11 phone cable
- Owner's guide

Materials You Need to Supply

Refer to [Figure 2 on page 12](#).

- Wire harness to connect the Link 1000 control panel to the shunt and to the positive battery terminal. You can use 18AWG, twisted pair, for this wiring. You can also buy the harness from the dealer you bought the Link 1000 from or from West Marine.

Contact West Marine at:

- 1-800-BOATING (Canada and US)
- Fax: 1-831-761-4421 (Canada and US)

When ordering the harness, quote these part numbers:

- 84-2014-00: 25 foot (7.62m) 8-conductor twisted pair wire
 - 84-2015-00: 50 foot (15.24m) 8-conductor twisted pair wire
 - Appropriately sized copper cable and connectors to connect the shunt to the battery and the negative bus for DC loads
- Consult a local cable supplier about cable size and connector type. You may find it convenient to have the cable supplier attach the connectors.
- 2, 2 amp fuses and fuse holders. (Three fuses and fuse holders if you are monitoring a second battery.)
 - 2 screws to mount the shunt

- 2 strain reliefs (cable clamps) for the wires and phone cable coming out the back of the control panel
- Anti-corrosive spray
- High current shunt. If your starter current exceeds 500 amps for more than ten seconds, you will need a heavy duty (1000 amp) shunt instead of the 500 amp shunt that is supplied with the Link 1000. (You can also use a separate engine starting battery whose negative is connected directly to the engine.) The heavy duty shunt part number is 84-2-13-00.

Tools

- Wire cutter and stripper
- Small slot head screwdriver (for the screws on the terminal block)
- Phillips screwdriver (for the control panel mounting screws)
- Needle-nose pliers
- 9/16 in. wrench to secure cables to the shunt

Installation Considerations

Safety

- If you are using flooded lead-acid batteries, install them in a separate battery compartment.
- Wiring should be in accordance with NEC, ABYC, or other applicable national or regional codes.

Performance

- Do not connect anything other than the shunt to the negative battery terminal. Connect all other loads and sources to the load side of the shunt. (See [Figure 2.](#))

- The shunt sense leads must be 18AWG twisted pair wires.
- Install fuses within seven inches (18cm) of the battery.

Color-Coded Wiring

To avoid confusion during installation, Xantrex recommends that you buy wires that have the same color coding as shown in [Figure 2](#).

Twisted Pair Wires

If you wish, you can make your own twisted pairs by twisting together two wires with a twist every inch. If you make your own twisted pair, wrap tape around the wires every twelve or sixteen inches (30 to 40cm) to keep the wires together and to make them easier to pull through holes and raceways.

Separate Engine Starting Battery

In order to monitor start battery voltage, you need to connect a sense lead from the Link 1000 terminal block to the positive battery terminal of the starting battery. This procedure also requires a 2 amp fuse and fuse holder. See step 6 on [page 16](#) for installation details, and see [page 33](#) for information about turning this function on.

Installing the Link 1000

Overview of Installation Steps

Complete the installation in this order. Refer to [Figure 2](#).

1. Mount the control panel ([page 13](#)).
2. Mount the shunt, and cable it to the negative battery terminal. Cable the load side of the shunt to the negative bus for DC loads ([page 14](#)).
3. Connect wires to the Link 1000 terminal block ([page 15](#)).
4. Connect wires from the terminal block to the shunt and to the battery's positive terminal ([page 16](#)).
5. Install the fuses ([page 17](#)).
6. Connect the phone cable to the control panel and the inverter/charger ([page 17](#)).

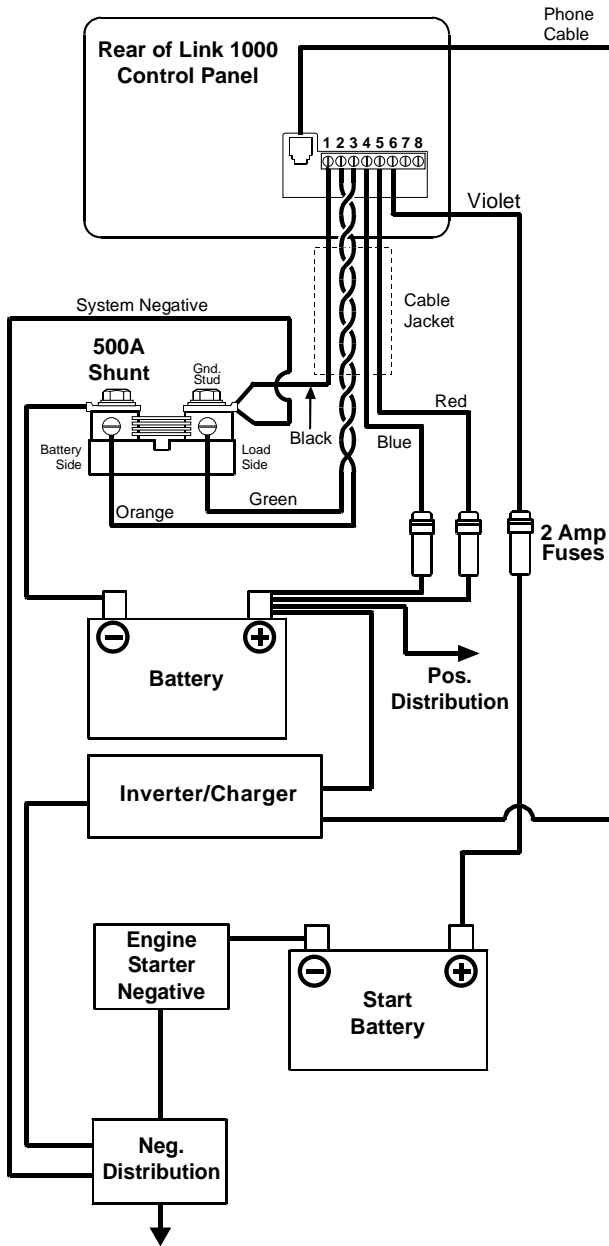

Figure 2 System Overview (Wiring)

Mounting the Link 1000 Control Panel

The Link 1000 control panel consists of a display panel and a mounting plate.

To mount the control panel:

1. Separate the display panel and the mounting plate.

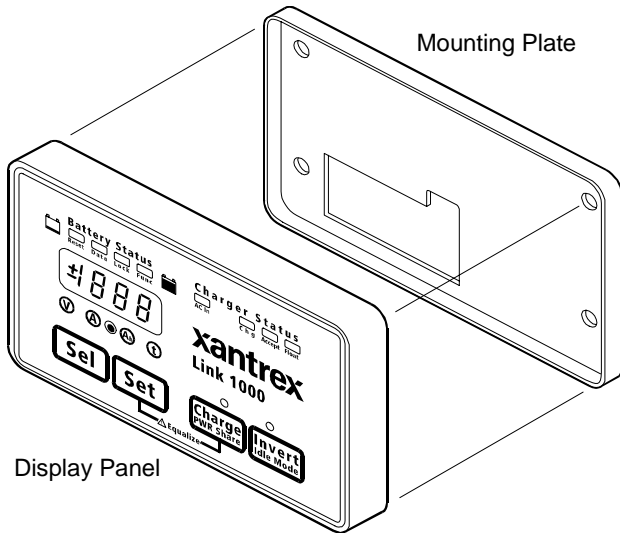

Figure 3 Display Panel and Mounting Plate

2. If you are going to run the phone cord and wires through the opening in the rear of the mounting plate, make a cutout in the mounting surface using the mounting plate as a template. (You can also run the phone cord and wires down from the bottom of the mounting plate.)
3. Screw the mounting plate to the mounting surface as shown in [Figure 4](#).

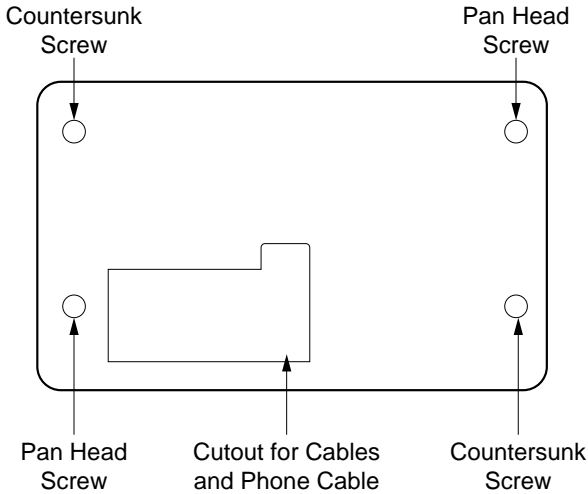

Figure 4 Link 1000 Mounting Plate

Mounting and Cabling the Shunt

To mount and cable the shunt:

1. Screw the shunt to a suitable mounting surface.
2. Connect the shunt to the negative terminal of the battery using ring terminals or locked spade terminals on a copper cable that is sized appropriately for the current carrying capacity of the system.

Ensure that no other wires are connected directly to the negative battery terminal or to the negative side of the shunt. All current must flow through the shunt.

3. Connect the load side of the shunt to the negative bus for DC loads using a copper cable that is sized appropriately for the current carrying capacity of the system.

If you are not using a negative bus for DC loads, connect the load side of the shunt to the negative side of the system.

Wiring the Terminal Block

Prepare for wiring by following these guidelines:

- Pull the wires and the phone cable through the opening in the mounting plate (unless you are running them down from the bottom of the mounting plate).
- Prepare the wires by giving each:
 - A clean cut
 - A clean strip
 - A tightly twisted end
- Loosen the terminal block screws, pry the wire clamps open with a paper clip, and insert the wires using needle-nose pliers.
- Tighten the screws firmly, but do not overtighten.

To wire the terminal block:

- Insert the wires in the terminal block following the sequence shown below.

Note: Terminal 1 is next to the phone cable jack.

Terminal	Wire Color and Function
1	Black. Control panel negative to the large bolt on the load side of the shunt.
2	Green. Sense lead to the load side of the shunt.
3	Orange. Sense lead to the battery side of the shunt.
4	Blue. Voltage sense lead to the positive battery terminal.
5	Red. Power lead to the positive battery terminal.
6	Violet. Voltage sense lead to the positive battery terminal. Connect this lead if you are monitoring the voltage of a second (starting) battery.
7	Not used
8	Not used

Connecting Terminal Block Wires to Shunt and Battery

To connect the terminal block wires:

1. Connect the black DC power wire (terminal 1) to the large bolt on the load side of the shunt. This wire should be on the top of the stack of large cables on the load side of the shunt. **Do not connect this wire to the small screw terminal with the green shunt sense lead.**
2. Connect the green lead (terminal 2) to the small screw on the load side of the shunt. This wire must be one half of the twisted pair made up of wires 2 and 3. Do not connect any other wires to this screw.
3. Connect the orange lead (terminal 3) to the small screw on the battery side of the shunt. This wire must be one half of the twisted pair made up of wires 2 and 3. Do not connect any other wires to this screw.
4. Connect the blue voltage sense lead (terminal 4) to a 2 amp fuse holder located within 7 in. (18 cm) of the battery. Connect the other side of the fuse holder to the positive battery terminal. Do not install the fuse yet.
5. Connect the red power wire (terminal 5) to a 2 amp fuse holder located within 7 in. (18 cm) of the battery. Connect the other side of the fuse holder to the positive battery terminal. Do not install the fuse yet.
6. If you are going to monitor a starting battery, connect the violet second battery voltage sense lead (terminal 6) to a 2 amp fuse holder located within 7 in. (18 cm) of the second (starting) battery. Connect the other side of the fuse holder to the positive battery terminal of the starting battery. Do not install the fuse yet.

Note: If you are going to monitor the starting battery, you must enable Function F11 during setup. See [page 33](#).

Installing Fuses

**CAUTION**

Install the fuses in the sequence listed below to prevent damage to the Link 1000.

To install fuses:

1. Install a 2 amp fuse in the fuse holder in the blue wire.
2. If you are using a starting battery, insert a 2 amp fuse in the fuse holder in the violet wire.
3. Install a 2 amp fuse in the fuse holder in the red wire. The fuse should be connected in a smooth motion. A “ragged” power up may cause the Link 1000 to lock up. The **BATTERY STATUS** LEDs and the Numeric Display come on. The **AC IN** LED comes on if AC power is being supplied to the inverter.

Connecting the Phone Cable

**CAUTION**

Make sure you have made all DC power and shunt connections before connecting the phone cable to the inverter/charger.

- Plug the phone cable into the jack on the display panel and the jack on the inverter/charger, and then clip the display panel into the mounting plate.

Testing the Installation

After installing the Link 1000, test its operation.

To verify that the shunt leads are connected correctly:

1. Select Amps as the display unit by pressing **SEL** until the Amps LED (A) comes on.
 2. Make a note of the Amps reading.
-

3. Turn the charger off.
4. Turn on a load (for example, a light bulb).
5. Make a note of the Amps reading.

It should be less than the reading you took in step 2. If it is not, the shunt leads are reversed (that is, the green wire from terminal 2 and the orange wire from terminal 3 are reversed).

Maintenance

Because the shunt senses very small currents, use an anti-corrosive spray to keep the leads free from corrosion. (Do not spray the leads at the terminal block end.)

Disconnecting the Inverter/Charger



CAUTION

If you need to disconnect the inverter/charger, unplug the phone cord from the inverter/charger before you remove the DC power and shunt connections.

3

Setting up the Link 1000

Chapter 3 explains:

- How to set up the Link 1000 to best suit your battery system
- Each setting as well as the options for each setting
- Whether you should change settings or leave the default setting

(See “[Reading the Link 1000 Control Panel](#)” on page 4 for locations and descriptions of the buttons, displays, and indicators on the Link 1000 control panel.)

About Link 1000 Settings

The Link 1000 is designed to operate out of the box, and except when noted, you shouldn't need to change the default settings. (The default settings are listed on [page 53](#).)

Probable Changes

You will probably need to change the default settings for:

- Battery capacity ([page 23](#))
- Battery type ([page 23](#))

Possible Changes

You may need to change the default settings for:

- Ambient temperature if your inverter/charger doesn't have a battery temperature sensor ([page 24](#)).
- Power sharing ([page 27](#))

Other Settings

Review this chapter completely to determine whether you need to change any other settings in order to monitor and control your battery system.

How to Enter Setup Mode and Change a Value

You must be in Setup mode to change settings.

To enter Setup mode and change a value:

1. Press and hold **SET** until SEL appears in the display (about three seconds). This puts you in Setup mode.
2. Press **SEL** until you reach the function you want.
3. Once you have selected the function you want, hold or repeatedly press **SET** to change the value.
4. Release **SET** when the value you want appears. After five to ten seconds, the display returns to normal. This indicates that the setting you chose is now stored in memory.

Locking Your Setup Values

After you have set up the Link 1000, you can lock the settings to prevent anyone from inadvertently changing them.

To lock the setup:

1. Hold down **SET** until SEL appears.
2. Press **SEL** until the **LOCK LED** comes on.
3. Press **SET**. The word ON or **OFF** appears
4. If OFF appears, press **SET** to turn the lock On.

Resetting Values

You can reset Ah to zero, or you can reset all values to their factory defaults:

- Resetting Ah to zero does not remove historical battery data.
- Resetting all values to factory defaults (Reset All) removes historical battery data. You usually use Reset All when you change a battery or a battery bank.

To reset values:

1. Hold down **SET** until SEL appears in the display.
2. Press **SET** five times until the **RESET LED** comes on and AH appears.
3. At this point you can reset Ah only, or you can Reset All:
 - To reset Ah only, press **SET** until ALL appears, and then release **SET**.
 - To restore all factory settings, press **SET** until ALL appears, and then continue to hold **SET** for another five seconds until 00. 0 appears quickly and disappears.

Battery Capacity

The default setting is for a battery with a 200Ah capacity. Change this setting if your battery has a different capacity.

You can test battery capacity by following the procedure on [page 42](#).

The most accurate way to find the capacity is to ask for the manufacturer's 20 hour rating.

Estimated Capacities for 12 Volt Flooded Batteries

The values listed below are estimates for 12 V flooded batteries except when noted.

Battery Size	Capacity (Ah)
U1	34–40
Group 24	80
Group 27	100
Group 30	120
Group 31	95–125
4-D	140–160
8-D	200
Golf cart & T-105 (6 volt)	120–220
L-16 (6 volt)	340–415

Estimated Capacities for Gel Cell Batteries

Gel cell batteries usually hold 15% fewer Ah for a given size. For example, a Group 27 gel cell stores about 85Ah.

Estimated Capacities for Multiple Batteries

Parallel Connection If you are using a single battery bank that consists of two or more batteries connected in parallel, multiply the Ah capacity of a single battery by the number of batteries used. For example, if three 12 volt Group 27 batteries are connected in parallel, use 300 Ah (100 Ah x 3) for the battery capacity.

Series Connection If you are using a single battery bank that consists of two or more batteries connected in series, use the Ah capacity of one battery. For example, if two Trojan T-105 6 volt golf cart batteries are connected in series, use the factory default 200 Ah for capacity.

Changing the Battery Capacity Setting

To change the Battery Capacity setting:

1. Press **SET** until SEL appears in the display.
2. Press **SEL** three times. The **A** LED comes on and 200 (the default) appears.
3. Press **SET** and hold it until the value you want appears.

Battery Capacity (Ah)	Incremental step in Ah
20 to 40	1
40 to 100	5
more than 100	20

Note: If you continue to hold **SET**, the display scrolls faster after four increments. If you go past your battery's capacity, you have to scroll to 1980Ah. The display then rolls over and begins scrolling up from 20Ah.

Changing the Battery Type Setting

Change the Battery Type setting if you are not using flooded lead-acid batteries. For details about battery types, see [page 33](#).

To change the Battery Type setting:

1. Press and hold **SET** until SEL appears.
2. Press **SEL** until Func F10 appears.
3. Press **SET** to select one of the following battery types: 0 (liquid cell), battery type 1 (gel cell, standard), battery type 2 (gel cell, fast charge), or battery type 3 (AGM – Absorbed Glass Mat).

Changing the Ambient Temperature Setting

When you have a battery temperature sensor: If you have a battery temperature sensor:

1. Leave the default Ambient Temperature setting as is.
2. Turn on Active Temperature Compensation (F16). (See [page 34.](#))

When you do not have a battery temperature sensor: If you do not have a battery temperature sensor, and if the temperature around the battery will be substantially different from 70 °F (21 °C) when the batteries are being charged:

1. Turn the Active Temperature Compensation setting Off. (See [page 34.](#))
2. Change the Ambient Temperature setting to an appropriate value.

Note: The Active Temperature Compensation setting must be Off if you are going to change the Ambient Temperature setting. Otherwise the Link 1000 reports the present battery temperature.

To change the Ambient Temperature setting:

1. Press and hold **SET** until SEL appears.
2. Press **SEL** until Func 03 appears.
3. Press **SET** to change the temperature in 10 °F increments.
4. Release **SET** when the correct temperature appears.

Charged Parameters

There are two charged parameters: Charged Voltage and Charged Current Percentage (%). During a charging cycle, when the battery voltage exceeds the Charged Voltage parameter and the charging current has dropped below the Charged Current parameter, the battery is considered to be fully charged. At this point the Link 1000 resets its state-of-charge to fully charged (which appears as 0 Ah on the display).

Changing the Charged Voltage Setting

If your system uses 12 or 24 Volt batteries: You don't need to change the default Charged Voltage setting. On power up, the Link 1000 automatically selects an appropriate Charged Voltage for 12 or 24 volt liquid cells and gel cells. (If you have gel cell batteries, see [“Changing the Battery Type Setting”](#) on page 23.)

If your system does not use 12 or 24 Volt batteries: You must set an appropriate Charged Voltage. Use a value of 2.2 volts per cell at normal temperatures for liquid cell batteries.

To change the Charged Voltage setting:

1. Press and hold **SET** until SEL appears.
2. Press **SEL** once. The  LED comes on and 13.2 appears (or 26.4 if you are using a 24 volt battery).
3. Hold down **SET** until the voltage you want is displayed. (The display moves up in 0.1 volt steps. Once the display reaches 50.0 volts, it then rolls over and starts counting up from 8.0 volts.)

Changing the Charged Current Percentage Setting

If your system's charging current does not fall below 2% of battery capacity at the end of the charging cycle (that is, when the battery should be full), you will need to change the Charged Current Percentage setting. (A fully charged battery is indicated when the green LED flashes on the **BATTERY STATUS** light bar.)

To change the Charged Current Percentage:

1. Press and hold **SET** until SEL appears.
2. Press **SEL** twice. The **(A)** LED comes on and 002 is displayed.
3. Press and hold **SET**.

The display moves up in one percent steps until 7 percent is displayed. The display then rolls over and starts counting up from 1 percent.

4. Release **SET** when the appropriate percentage appears.

Changing the Time Remaining Setting

The Link 1000 has four ways of calculating the amount of operating time that remains. You can select:

- Present consumption level
- A four minute average
- A sixteen minute average
- A thirty-two minute average

The best setting depends on your type of installation. The four minute average is appropriate for most installations.

To change the Time Remaining setting:

1. Press **SET** until SEL appears.
2. Press **SEL** four times until the **(t)** LED comes on and 001 appears.
3. Press **SET** until the number you want appears. The display moves up in 1 unit steps with choices of:

000	Present consumption
001	4 minute average
002	16 minute average
003	32 minute average

4. Release **SET** when the value you want appears.

Changing the Power Share Setting

Power Share is a load management feature that helps to prevent external source AC breakers from tripping when the charger and a number of other loads all come on at once. Power Share automatically reduces the charger output if the loads exceed the Power Sharing current limit.

When you plug in to an external AC power supply, set the Power Share level to the breaker size.

If your charger trips the shore power breaker, choose a lower Power Share setting.

To change Power Share values:

Note: The **CHARGE** button LED must be on before you can change Power Share values.

1. Press and hold **SET** until SEL appears.
2. Press the **CHARGE/PWR SHARE** button. The present value appears.
3. Press and hold **SET** until the display begins scrolling through other values.
4. Release **SET** when the value you want appears.

Changing the Idle Mode Setting

The Idle mode setting determines the size of AC load that is needed to wake the inverter from its Idle (or standby) mode.

The settings are 0 W, 4 W, 6 W, and 15 W. The default is 4 W.

If you set the Idle mode to 0 W, Idle mode is actually defeated and the inverter stays on all the time. When the inverter is on, it draws approximately 0.5 amps. This setting is useful if you want to ensure uninterrupted power to a very small load like an electric clock.

The other three settings let you conserve battery power because the inverter stays off until an adequate-sized load brings the inverter out of Idle mode.

To change the Idle mode setting:

Note: The **INVERT** button LED must be on before you can change the Idle mode setting.

1. Press and hold **SET** until SEL appears.
2. Press the **INVERT/IDLE MODE** button. The present value appears.
3. Press and hold **SET** until the display scrolls through the other values.
4. Release **SET** when the value you want appears.

Advanced Function Values

The Link 1000 has sixteen advanced functions. The default setting is appropriate for most, and you should not change a value unless you understand the consequence of the change.

Note: If you are monitoring more than one battery:

- Change Function F11, Second Battery Voltage Sense.
- Record the software revision number on [page 60](#). (See “F15 Display Software Revision Number” on [page 34](#).)

How to Enter Setup Mode and Change a Value: Reminder

The procedure for entering Setup mode and changing a value is given on [page 20](#).

F01 Auto Display Scanning

Default: Off

Range: Off, On

When Auto Display Scanning is On, the display automatically scrolls through Volts, Amps, Ah, and Time remaining. Each value is displayed for four seconds.

If Second Battery Voltage Sense (F11) is also on, two voltages are shown. The flashing Volts status LED  indicates that the voltage displayed is that of the second battery bank.

F02 Display Sleep

Default: On

Range: On, Off

This function turns off the Numeric Display and the Display Units LEDs. All the other LEDs—**BATTERY STATUS** light bar, **AC IN**, Charger status LEDs, **CHARGE LED**, and **INVERT LED**—stay on.

F03 Set or Display Ambient Battery Temperatures

Default: If F16 (Active Temperature Compensation) is On, the present battery temperature is displayed in °F. If F16 is Off, the declared battery temperature is displayed.

Range: 30° F–120° F (–1.11° C–48.8° C) in 10° increments.

Set a different value from the default only if the battery environment is significantly different from 70° F (21.11° C) when the batteries are being charged by the Freedom Inverter/Charger.

For more information about battery charging and temperature compensation, see [“F07 Set Temperature Coefficient” on page 31](#).

F04 Toggle Display Between Ah and kWhr

Default: Off

Range: Off = Ah display mode; On = kWhr display mode.

When this function is On, the Ah display is changed to a kilowatt-hour display.

Kilowatt-hours are a very precise measurement of energy removed from or returned to the battery bank. The Link 1000 uses kilowatt-hours to determine whether 100% of the energy consumed from the battery has been returned.

A recalculation of the CEF (Charge Efficiency Factor) is not permitted unless this counter is greater than 0.00 kWhr. This counter counts down during discharge, and the kWhrs consumed are displayed with a negative number. While the battery is charging, the Link 1000 counts back up with 100% efficiency. CEF recalculation is prevented until a positive number is in the kWhr counter. This prevents a premature CEF reset.

F05 Turn on Alternative Energy Mode

Default: Off

Range: Off and On. On = use alternative energy defaults.

Turn Alternative Energy mode on if the Link 1000 is used in an alternative energy system.

This function reduces the time needed to satisfy the charged parameters from five minutes to one minute. If you are using a semi-mechanical photovoltaic controller, we strongly recommend that you also consider changing Charged Current to 4%. (See [“Changing the Charged Current Percentage Setting”](#) on page 25.)

F06 Manually Set CEF

Default: Off = Auto recalculation of CEF

Display: A95

Range: 65–99 in 1 number increments

This setting allows manual set up of CEF (Charging Efficiency Factor). The default display A95 indicates the automatic CEF recalculation feature. Returning to A95 from a user-set CEF turns the automatic CEF feature back on. If a user-set CEF has been selected, it will appear as a Uxx in Data mode (where xx is the number the user has selected).

F07 Set Temperature Coefficient

Default: 0.5

Range: 0.1–0.5 in 0.1 step increments

We recommend that you use the default value.

This factor compensates for the impact that temperature has on battery capacity. A typical value is 0.5% Capacity per °C. This coefficient must be supplied by the battery manufacturer. The default value is typical for liquid lead-acid or gel batteries.

F08 Set Peukert's Exponent

Default: 1.25 for liquid lead-acid batteries. (Battery Type set to Type 0.)

The Peukert exponent refers to the “shrink rate” of your battery bank. The more rapidly you discharge the batteries, the more their effective size shrinks. For example, a battery that can supply 200Ah when discharged over twenty hours may only provide 95Ah if discharged in one hour.

When you select Battery Type (see [“Changing the Battery Type Setting” on page 23](#) and [“F10 Select Battery Type” on page 33](#)), the Link 1000 automatically sets an appropriate Peukert exponent. When the Battery Type is gel or AGM (Type 1, 2, or 3), a default exponent of 1.11 is used.

If your battery manufacturer has given you another value, you can enter it. Otherwise, leave the default value.

F09 Set Low Battery Discharge Floor

Default: 100%

Range: 50%–100% in 5% increments

The Link 1000 lets you set the discharge floor that it uses for calculations. The factory-set discharge floor is 100% of Ah capacity, corrected for high discharge rates. If you set the discharge floor to 100%, the Time Remaining display ⓘ reports the time that remains until you have a dead battery. We recommend that you begin charging when two yellow battery status LEDs are on in order to conform to the “Mid Capacity Rule” (see [page 39](#)).

Note: If you discharge below the discharge floor, and then partially charge but remain below the discharge floor, the Time Remaining display will continue to read zero. The Time Remaining display will not show meaningful readings until you have recharged above the discharge floor you have set.

F10 Select Battery Type

Default: 0 (Liquid Cell)



Range: 0 = Liquid Cell; 1 = Gel Cell (standard); 2 = Gel Cell (fast charge); 3 = AGM (Absorbed Glass Mat)

This function sets the appropriate charge and float voltages for the Freedom charger and sets an appropriate Peukert exponent. Gel cell owners can use Type 1 or Type 2, but should consult the battery manufacturer before using Type 2. Type 3 sets Acceptance and Float voltages suited to AGM type batteries.

F11 Turn on Second Battery Voltage Sense

Default: Off

Range: On, Off

When this function is On, two voltages are displayed. When the Volts LED  is on solid, you see the voltage of the monitored battery. If the battery Volts LED  is flashing, the second (starting) battery voltage is being displayed.

If you use this function, keep in mind that the displayed voltage is only an indication of the battery's state-of-charge if the battery has been at rest for at least eight hours.

A battery with an eight hour at-rest voltage of 12.4 volts or more will probably start an engine. A battery with an eight hour at-rest voltage of 11.1 volts will probably not start an engine, particularly if you have dirty injectors and if the engine doesn't start right away.

F12 Number of Overload Conditions Experienced

Displays the number of inverter shutdowns since the last high level meter reset. This is primarily a troubleshooting tool.

F13 Number of Inverter Low Battery Shutdowns

Displays the number of inverter low battery shutdowns since the last high level meter reset. This is primarily a troubleshooting tool.

F14 Test Control Panel Display

Default: Off

Range: On while the **SET** button is pressed when this function is active. Off when **SET** is released.

This function lets you confirm that the Link 1000 control panel display is operating properly. When you press **SET** in F14 mode:

- The **RESET** and **DATA** LEDs are orange-yellow.
- All other LEDs display their normal color.
- The Numeric Display reads 188. 8.

The display returns to normal when you release **SET**. Operation of the **LOCK** and **FUNC** LEDs is confirmed when power is initially applied to the Link 1000.

F15 Display Software Revision Number

- Press **SET** to display the Software Revision Number.

This function displays the software revision number installed in your Link 1000. Record this number on [page 60](#) in case you need to call Customer Service.

F16 Turn on Active Temperature Compensation

Default: Off

Range: Off, On

Turn this function On if your inverter/charger has a temperature sensor.

Leave this function Off if you are not using a temperature sensor.

When this function is On, the Link 1000 uses the actual battery temperature reported to the Freedom Inverter/Charger by a Heart TC2+2 unit, the Freedom 458 or the Freedom Marine Inverter/Charger temperature sensor.

4

Using the Link 1000

[Chapter 4](#) tells you how to:

- Read the battery's state-of-charge
- Turn on the invert function
- Change the Idle mode setting
- Charge and equalize the batteries
- Determine battery capacity
- Activate the Power Share feature
- Synchronize the Link 1000 to the batteries
- Read battery history
- Respond to Error Codes

Monitoring Functions

Choosing a Display Unit: Volts, Amps, Ah, or Time

By default, the numeric display shows Volts V , but it can also show Amps, Ah, and Time Remaining.

To change the display unit:

- Press **SEL** until the A , Ah , or t LED comes on.

The units of display are explained below.

- | | |
|------------------------------|--|
| V VOLTS | Displays the voltage of the battery being monitored. (The Link 1000 can also display the voltage of an additional battery.) |
| A AMPS | Displays the flow of current into or out of the battery. Discharging appears as a negative number. Charging appears as a positive (unsigned) number. For example, if 6 amps are going into the battery, the numeric display shows 6 . If 6 amps are being consumed, the numeric display shows -6 . |
| Ah Ah | Displays the Ah (amp-hours) consumed. This is the amount of energy that has been consumed from the battery. For example, if you have operated a 10 amp load for one hour, 10 Ah have been consumed, and the display shows -10 . When the battery is fully charged, the Link 1000 displays 0 Ah. |
| t TIME
REMAINING | This is an estimate of the hours that the battery can operate at its present load until it is completely discharged. The estimate is based on a selectable, time- averaged, rate of discharge. The default is the average of the last four minutes of use. While the batteries are charging, this display shows CCC . |

Note: The numeric display also shows Error Codes. If an error occurs, the display alternates between the monitoring function you have selected and the Error Code. For details about Error Codes, see [page 48](#).

Reading the Battery State-of-Charge

The **BATTERY STATUS** light bar (see [Figure 5](#)) shows the battery's state-of-charge. The table explains how to read the light bar.

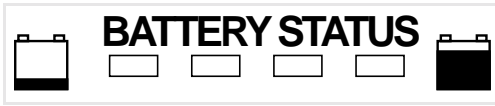

Figure 5 BATTERY STATUS Light Bar

These lights	Indicate this %
3 green + 1 flashing green	The CEF has been recalculated.
4 green	80–100%
3 green	60–79%
2 yellow	40–59% Enough charge to start an engine-driven charging source.
1 red	20–39%
1 flashing red	0–19% The battery is more than 80% discharged (based on the factory settings).

Scaling the BATTERY STATUS Light Bar

You can scale the **BATTERY STATUS** light bar to show a flashing red LED when your battery is more than 40% discharged. To adjust the battery discharge floor, see [page 32](#).

Inverter Functions

Turning on the Invert Function

When the inverter is operating, power is taken from the batteries and converted to AC current to power your loads.

To turn on the invert function:

- Press **INVERT**.

The **INVERT** button LED comes on.

The **INVERT** LED does not indicate that the system is inverting. It indicates that the invert function is enabled. The invert function only operates when the inverter is connected to the battery, no external AC power is available, and the batteries have enough power for the loads.

When the inverter is initially powered up, the invert function is off.

Changing the Idle Mode Setting

The Idle mode setting determines the size of AC load that is needed to wake the inverter from its Idle (or standby) mode.

To change the Idle mode setting:

- See [page 28](#).

Charging Functions

Charge your batteries when two yellow LEDs are lit on the **BATTERY STATUS** light bar (if you are using the default setting for F09: Low Battery Discharge Floor). The two yellow LEDs indicate that 50% of battery capacity has been used.

Charging at this level is called the Mid-Capacity Rule. In marine and RV systems, which try to minimize charging time with an engine-driven alternator, or generator-powered charging, the battery is normally charged to the 85% level. This means that only 35% of the battery capacity is actually available for use.

The Mid-Capacity Rule is designed to optimize battery life.

Four charging cycles are available: Bulk, Acceptance, Float, and Equalization. When you start a charge cycle, the charger automatically completes a Bulk, Accept, and Float charge. You can also start an Equalization charge manually.

The **CHARGER STATUS** LEDs are explained below, and then procedures are given for charging and equalizing the batteries.

Summary of CHARGER STATUS LEDs

This LED	Indicates
AC IN (green)	AC power is present.
CHG (red) on solid	The batteries are in Bulk charge mode.
CHG (red) flashing	An Equalization charge is being applied.
ACCEPT (orange)	The batteries are in Acceptance mode.
FLOAT (green)	The charge is in Float mode.

Charging the Batteries

To start a charge cycle:

- Press the **CHARGE** button. (You can also leave the **CHARGE** button on, and the cycle will start automatically.)

The **CHG** LED and the **CHARGE** button LED come on.

The charger automatically cycles through the Bulk, Acceptance, and Float charge stages.

The charge function only operates when the inverter is connected to a battery and external AC is available.

(On inverter/chargers that have a serial number lower than 100,000, charging is enabled when the **INVERT** button is on.)

Equalizing the Batteries

Equalization is the controlled overcharging of a lead-acid battery (or battery bank) to remove lead sulfate that is not removed during normal charging. Controlled overcharging helps the battery reach and maintain peak capacity by equalizing the chemistry in the individual battery cells.

- Equalize your batteries every thirty days when they are in a daily cycling service or every thirty deep cycles.
- Equalize your batteries when the battery capacity has decreased (that is, when the batteries do not hold loads as well as they previously did).

Precautions



WARNING: Explosion Hazard

Equalization produces explosive gases which must be vented.

Read these precautions before you start an equalization charge:

- Equalization causes batteries to gas. Make sure they are well ventilated.

- Check the electrolyte level of all batteries before and after equalization. Make sure the electrolyte is at the correct level, but do not overfill because the electrolyte may expand and overflow.
- Leave the filler caps screwed on loosely, or remove them and cover the opened cell tops with a folded paper towel.
- Make sure you are present during equalization so you can monitor the charging cycle.

To start an equalization cycle:**CAUTION**

Turn off all DC loads before you start equalization. The voltages required during equalization can damage sensitive equipment.

1. Make sure the charger is on and the batteries are fully charged.
2. Press **SET** until **SEL** appears.
3. Press **SET** and **CHARGE** simultaneously until the **CHG** LED starts flashing and **OOE** goes out (about five seconds). The **CHG** LED flashes throughout the equalization cycle.

To end an equalization cycle manually:

- Press **SET** until **SEL** appears, and then press **SET** and **CHARGE** simultaneously.
The **CHG** LED goes out and the Freedom Inverter/Charger is forced to float when equalization ends (the **FLOAT** LED comes on).

If you do not stop the equalization process manually, the cycle ends automatically after eight hours. It also ends if external AC power is interrupted.

To end equalization early on Freedom inverters that have a serial number lower than 100,000, turn off both the **CHARGE** and **INVERT** buttons.

Equalizing Gel Cell Batteries

You don't normally equalize gel cell batteries. If they have been severely discharged, however, this may be the only way to get them to begin accepting a charge. The voltage is limited to the Acceptance charging level, but the cycle lasts for eight hours.

Be sure that battery type is set to 002 before you equalize gel cell batteries.

Activating Power Share

Power Share is a load management feature that helps prevent external source AC breakers from tripping when the charger and a number of other loads all come on at once. Power share automatically reduces the output of the Freedom Inverter/Charger if the AC loads exceed a specified current limit.

To change the Power Share setting:

- See [page 27](#).

Battery Capacity Testing

To determine the actual amount of energy your batteries can store, you conduct periodic capacity tests. A capacity test should start with a battery that has been properly charged and equalized.

Deep cycle battery capacity is usually stated as a 20 hour discharge rate (a 100 Ah battery will provide 5 amps for twenty hours). At discharge rates above 5 amps, the battery will supply less than 100 Ah. For example, if you are drawing 100 amps out of the battery, it will last less than half an hour. The following table shows battery capacity at various discharge rates.

Battery Capacity at Various Discharge Rates

Hours to Discharge	Capacity (as a percent of the 20 hour rate)
20	100%

Battery Capacity at Various Discharge Rates

Hours to Discharge	Capacity (as a percent of the 20 hour rate)
10	89%
5	78%
3	66%
1	45%

To test battery capacity:

1. Charge the battery until the charged parameters are met. This resets Ah to zero.
2. Turn on a load that draws approximately 5% of the expected battery capacity.
3. Check the current by looking at the Amps display. The load should be constant (for example, a light bulb).
4. Put the Link 1000 in Volts V display mode.
5. When the voltage drops to 10.5 volts (or 21 volts if you are testing a 24 volt system), turn the load off. (It should take about twenty hours for the voltage to drop.)
6. Look at the Ah Ah display. The number of Ah displayed is the actual battery capacity.

If less than twenty hours passed before the voltage fell to 10.5, you can still determine the capacity by completing a simple calculation. For example, assume that you have a 12 volt battery rated at 100 Ah. Apply a 5 amp load. If it only took ten hours for the voltage to reach 10.5, the Link 1000 would display –50Ah. This number is the 10 hour capacity.

By dividing 50 by 89% (see the preceding table), you determine that the actual 20 hour capacity is 56 Ah. You could repeat the test at 5% of the tested capacity (2.8 amps) to verify the actual capacity.

Synchronizing the Link 1000 to the Battery

When the battery is fully charged, the Link 1000 displays 0 Ah. This indicates that no energy has been removed from the battery. (The display can also show a positive number; this changes to 0 as soon as you place a load on the battery. See [page 45](#) for details about over-charge Ah).

As the battery discharges, the display shows how much energy has been used. For example, when you run a 10 amp load for one hour, the display shows -10 to indicate that 10 Ah have been used.

In other words, the Ah display tells you how much energy has been removed from the battery as long as the Link 1000 is synchronized with the battery.

- If you install the Link 1000 on a fully charged battery, it is automatically synchronized to the battery.
- If you install the Link on a battery that is partially charged, you must synchronize the Link by following the procedure given here.
- Once the Link 1000 is synchronized, it stays synchronized as the battery runs through discharge / charge cycles. If the Link ever gets out of sync with the battery (this rarely happens), you can synchronize it once again by following the procedure given here.

To synchronize the Link 1000 to the battery:

1. Discharge the battery by at least 10% of its declared capacity.
2. Set the Ah reading to 0 by:
 - a) Holding down **SET** until SEL appears in the display.
 - b) Pressing **SET** five times until the **RESET** LED comes on and AH appears.
 - c) Pressing **SET** until ALL appears. (Be sure to release **SET** as soon as ALL appears.)
4. Charge the battery until the green **FLOAT** LED comes on. (For battery charging procedures, see [page 40](#).)

Overcharge Ah are displayed as a positive number. When the battery starts to discharge, the Link resets Ah to zero.

Over-charge Ah (Accumulation of Positive Ah)

If the battery is 100% charged, and the Link 1000 is synchronized with the battery, over-charge Ah are displayed as a positive Ah number. Some accumulation of over-charge Ah is normal with systems that are continuously connected to a charger. For example, a 100 Ah battery at Float voltage will normally have a little less than 0.1 amps flowing into it. This means you would expect about 2.4 Ah of over-charge to accumulate each day. If your battery system is larger, more current flows and more over-charge Ah accumulate.

If the charging system is a constant voltage type set at 14.2 volts, as much as 1 amp may be flowing all the time after the battery has reached the charged parameters. Prolonged high voltage applied to a fully charged battery will likely cause gassing, and you would expect to see a large Ah over-charge every day. This indicates that you are shortening the life of your battery by over charging. Check your Link 1000 before turning off a charging source to see that you have not accumulated too many over-charge Ah. (When discharging begins, the Link 1000 resets to zero and begins to report Ah consumed.)

If you equalize your batteries, some over-charge Ah will accumulate. This is normal and ensures that the Link 1000 stays synchronized with the battery state-of-charge.

Battery History

The Link 1000 stores four kinds of information about the battery.

To access battery history:

1. Hold down **SET** until **SEL** appears.
2. Press **SEL** until the **DATA LED** comes on.
E99 is displayed. This is the Charging Efficiency Factor (CEF).
3. Press **SEL** again.
+l 999 is displayed. This is the number of CEF Recalculations.
4. Press **SEL** again.
-999 is displayed. This is the Deepest Depth of Discharge.
5. Press **SEL** again.
i 999 is displayed. This is the Average Depth of Discharge.

Interpreting Battery History

E99: Charging Efficiency Factor The Charging Efficiency Factor (CEF) is the energy efficiency of the battery. This indicates the health of the battery. The lower the efficiency, the worse the health of the battery.

The Ah CEF, not the kilowatt-hour CEF, is displayed. A display of E99 indicates a 99% CEF based on Ah. The Default setting is 95%.

If the CEF display has a u in front of it, this means the CEF has been selected by the user. See [page 31](#) for details about changing the CEF settings.

+I999: Number of CEF Recalculations This is the number of times the battery has been discharged more than 10% and then completely recharged (recharged until the Charged

Parameters have been met) since the last time it was reset to the factory defaults. A discharge of less than 10% of battery capacity is not counted as a “cycle”.

-999: Deepest Discharge This is the deepest discharge in Ah since the last time the Link 1000 was reset to the factory defaults.

i999: Average Discharge This is the average of all discharges as an Ah value since the last reset to factory defaults. For best battery life, you should not routinely discharge more than 50% of your battery’s capacity. If you do, you shorten its life. An average discharge of 500Ah on a 900Ah battery is demanding but not unreasonable. An average discharge of 180Ah from a 200Ah battery is excessive and will shorten the battery’s life.

Reading Error Codes

When the Link 1000 detects a problem, an error code appears in the numeric display. The display alternates between showing the monitoring function you have selected and the error code. The error code flashes until the error is corrected.

The following table lists each Error Code, describes the cause of the error, and indicates the action to take, if any.

Error Code	Meaning
E01	<p>High battery voltage shutdown (Inverter/charger error) Battery voltage has risen above 15.5 V for 12 V inverters or above 31 V for 24 V inverters. Check all charging sources (that is, solar panels, alternators, etc.)</p>
E02	<p>Low battery voltage shutdown (Inverter/charger error) Battery voltage has dropped below 10.5 V for 12 V inverters or below 21 V for 24 V inverters. Check for a dead battery or poor battery connections.</p>
E03	<p>Over temperature shutdown (Inverter/charger error) The inverter has overheated and shut down. It will reset automatically after it has cooled sufficiently. Make sure there is adequate ventilation around the inverter.</p>
E04	<p>Battery overload (Inverter/charger error) The battery is excessively discharged or there is a shorted battery. See your inverter/charger owner’s manual for information about charging excessively discharged batteries.</p>

Error Code	Meaning
E05	<p>AC backfeed (Inverter/charger error) AC power from an outside source has been fed to the AC output of the inverter. This could damage the inverter. Disconnect incoming AC power and correct the fault immediately. Consult a qualified electrician if you do not know how to diagnose and treat this problem.</p>
E06	<p>Electronic overload (Inverter/charger error) The inverter is connected to a load that is too large for it, or the inverter output has shorted out. Remove the load. Reset the inverter by cycling the charger on and off, or connect AC power from an outside source.</p>
E07	<p>Triac control error (Inverter/charger error) A switch inside the charger has overheated. Turn the charger off and let it cool. Make sure there is adequate ventilation around the inverter.</p>
E08	<p>High battery voltage shutdown during charging (Inverter/charger error) Check all charging sources (solar panels, alternators, other battery chargers, etc.) for proper voltage. Reset the inverter by cycling the charger off and on.</p>
E09	Spare
E010	<p>Depowered (Link 1000) This code appears when the Link 1000 is first powered up and whenever power has been interrupted or has dipped below the operating voltage of the Link 1000. This code can be triggered by voltage dips during engine starting if the Link 1000 is powered by the same battery that starts the engine.</p>
E011	Spare

Error Code	Meaning
E012	<p>Battery voltage sense lead open (Link 1000) Check the fuse or any other connections in the voltage sense lead (blue wire) to the battery.</p>
E013	Spare
E014	<p>Inappropriate charged voltage selected for the sensed voltage (Link 1000) This code appears if the Charged Voltage parameter is above 20 V and the sensed voltage is below 20 V, or if the sensed voltage is above 20 V and Charged Voltage parameter is below 20 V. This code will help you avoid an incorrect setup.</p>
E015	<p>Incoming AC polarity reversed (Inverter/charger error) Check the incoming AC wiring for reversed polarity (positive and neutral reversed). Consult a qualified electrician if you do not know how to diagnose and correct this condition.</p>
0L	<p>Link 1000 reading out of range (Link 1000)</p>

A

Specifications

[Appendix A](#) lists:

- Electrical and physical specifications for the Link 1000
- Default settings

Specifications are subject to change without notice.

Control Panel: Electrical Specifications

DC Power supply voltage	8–40 VDC. (Not for use with 32 volt systems.)
Power consumption	For 12 volt systems: <ul style="list-style-type: none"> • 90 mA (typical) • 170 mA (full display brightness) • 25 mA (sleep mode; only BATTERY STATUS LEDES on.) Values are approximately half on 24 volt systems.
Voltage measurement range	0.1–50 VDC
Voltage resolution	0.05 VDC
Voltage accuracy	±0.10 VDC at full scale
Current measurement range	±500 Amps DC
Current resolution	<ul style="list-style-type: none"> • 0.1 amp DC (from ±0–±42.0 amps) • 1 amp DC (from ±42–±500 amps)
Current accuracy	<ul style="list-style-type: none"> • ±0.1 amp DC at full scale low range • ±1 amp DC at full scale high range
Current shunt	±0.25% ratio: 50mV @ 500A
Amp hour range	±1,999Ah
Time remaining range	255 hours maximum

Control Panel: Physical Specifications

Width	4.725 in. (120 mm)
Height	2.975 in. (75.5 mm)
Depth	1.075 in. (27.3 mm)
Weight	4.6 oz. (2 g)
Front panel finish	Water resistant, splash proof

Default Settings

Inverter/Charger Controls

CHARGE	On
INVERT	Off
Idle Mode	4 Watts (5 Watts on Series 458 units)
Power Sharing	30 amps (Off for Freedom 25 units)

Monitoring Functions

Charged Voltage	13.2 volts for 12 volt systems 26.4 volts for 24 volt systems
Charged Current	2% (of battery capacity, 4 amps @ 200 Ah)
Battery Capacity	200Ah
CEF	95% (Charge Efficiency Factor)
Ambient Temperature	70 °C
Battery Type	0 (liquid cell)
Peukert Exponent	1.25

B

Product and System Information

[Appendix B](#) contains:

- The warranty for your Link 1000
- Instructions for returning the product for servicing
- A table (see [page 61](#)) where you can record information about your system in case you need to contact Customer Service

Warranty

What does this warranty cover? This warranty is provided by Xantrex Technology Inc. (“Xantrex”) and covers defects in workmanship and materials in your Xantrex Link 1000 Battery Monitor. This warranty lasts for a Warranty Period of 12 months from the date of purchase at point of sale to you, the original end user customer.

This Limited Warranty is not transferable.

What will Xantrex do? Xantrex will, at its option, repair or replace the defective product free of charge, provided that you notify Xantrex of the product defect within the Warranty Period, and provided that Xantrex through inspection establishes the existence of such a defect and that it is covered by this Limited Warranty.

Xantrex will, at its option, use new and/or reconditioned parts in performing warranty repair and building replacement products. Xantrex reserves the right to use parts or products of original or improved design in the repair or replacement. If Xantrex repairs or replaces a product, its warranty continues for the remaining portion of the original Warranty Period or 90 days from the date of the return shipment to the customer, whichever is greater. All replaced products and all parts removed from repaired products become the property of Xantrex.

Xantrex covers both parts and labor necessary to repair the product, and return shipment to the customer via a Xantrex-selected non-expedited surface freight within the contiguous United States and Canada. Alaska and Hawaii are excluded. Contact Xantrex Customer Service for details on freight policy for return shipments outside of the contiguous United States and Canada.

How do you get service? If your product requires troubleshooting or warranty service, contact your merchant. If you are unable to contact your merchant, or the merchant is unable to provide service, contact Xantrex directly at:

Phone: 1-800-670-0707 (toll-free in North America) 1-604-422-2777 (direct)

Fax: 1-604-420-2145

Email: CustomerService@xantrex.com

Direct returns may be performed according to the Xantrex Return Material Authorization Policy described in your product manual. For some products, Xantrex maintains a network of regional Authorized Service Centers. Call Xantrex or check our website to see if your product can be repaired at one of these facilities.

In any warranty claim, dated proof of purchase must accompany the product and the product must not have been disassembled or modified without prior written authorization by Xantrex.

Proof of purchase may be in any one of the following forms:

- The dated purchase receipt from the original purchase of the product at point of sale to the end user, or
- The dated dealer invoice or purchase receipt showing original equipment manufacturer (OEM) status, or
- The dated invoice or purchase receipt showing the product exchanged under warranty

What does this warranty not cover? This Limited Warranty does not cover normal wear and tear of the product or costs related to the removal, installation, or troubleshooting of the customer's electrical systems. This warranty does not apply to and Xantrex will not be responsible for any defect in or damage to:

- a) the product if it has been misused, neglected, improperly installed, physically damaged or altered, either internally or externally, or damaged from improper use or use in an unsuitable environment;
- b) the product if it has been subjected to fire, water, generalized corrosion, biological infestations, or input voltage that creates operating conditions beyond the maximum or minimum limits listed in the Xantrex product specifications including high input voltage from generators and lightning strikes;
- c) the product if repairs have been done to it other than by Xantrex or its authorized service centers (hereafter "ASCs");
- d) the product if it is used as a component part of a product expressly warranted by another manufacturer;
- e) the product if its original identification (trade-mark, serial number) markings have been defaced, altered, or removed.

Disclaimer

Product

THIS LIMITED WARRANTY IS THE SOLE AND EXCLUSIVE WARRANTY PROVIDED BY XANTREX IN CONNECTION WITH YOUR XANTREX PRODUCT AND IS, WHERE PERMITTED BY LAW, IN LIEU OF ALL OTHER WARRANTIES, CONDITIONS, GUARANTEES, REPRESENTATIONS, OBLIGATIONS AND LIABILITIES, EXPRESS OR IMPLIED, STATUTORY OR OTHERWISE IN CONNECTION WITH THE PRODUCT, HOWEVER ARISING (WHETHER BY CONTRACT, TORT, NEGLIGENCE, PRINCIPLES OF MANUFACTURER'S LIABILITY, OPERATION OF LAW, CONDUCT, STATEMENT OR OTHERWISE), INCLUDING WITHOUT RESTRICTION ANY IMPLIED WARRANTY OR CONDITION OF QUALITY, MERCHANTABILITY OR FITNESS FOR A PARTICULAR PURPOSE. ANY IMPLIED WARRANTY OF MERCHANTABILITY OR FITNESS FOR A PARTICULAR PURPOSE TO THE EXTENT REQUIRED UNDER APPLICABLE LAW TO APPLY TO THE PRODUCT SHALL BE LIMITED IN DURATION TO THE PERIOD STIPULATED UNDER THIS LIMITED WARRANTY.

IN NO EVENT WILL XANTREX BE LIABLE FOR ANY SPECIAL, DIRECT, INDIRECT, INCIDENTAL OR CONSEQUENTIAL DAMAGES, LOSSES, COSTS OR EXPENSES HOWEVER ARISING WHETHER IN CONTRACT OR TORT INCLUDING WITHOUT RESTRICTION ANY ECONOMIC LOSSES OF ANY KIND, ANY LOSS OR DAMAGE TO PROPERTY, ANY PERSONAL INJURY, ANY DAMAGE OR INJURY ARISING FROM OR AS A RESULT OF MISUSE OR ABUSE, OR THE INCORRECT INSTALLATION, INTEGRATION OR OPERATION OF THE PRODUCT.

Exclusions

If this product is a consumer product, federal law does not allow an exclusion of implied warranties. To the extent you are entitled to implied warranties under federal law, to the extent permitted by applicable law they are limited to the duration of this Limited

Warranty. Some states and provinces do not allow limitations or exclusions on implied warranties or on the duration of an implied warranty or on the limitation or exclusion of incidental or consequential damages, so the above limitation(s) or exclusion(s) may not apply to you. This Limited Warranty gives you specific legal rights. You may have other rights which may vary from state to state or province to province.

Warning: Limitations On Use

Please refer to your product user manual for limitations on uses of the product. Specifically, please note that the Xantrex Link 1000 Battery Monitor is not intended for use in connection with life support systems and Xantrex makes no warranty or representation in connection with any use of the product for such purposes.

Return Material Authorization Policy

Before returning a product directly to Xantrex you must obtain a Return Material Authorization (RMA) number and the correct factory "Ship To" address. Products must also be shipped prepaid. Product shipments will be refused and returned at your expense if they are unauthorized, returned without an RMA number clearly marked on the outside of the shipping box, if they are shipped collect, or if they are shipped to the wrong location.

When you contact Xantrex to obtain service, please have your instruction manual ready for reference and be prepared to supply:

- The serial number of your product
- Information about the installation and use of the unit
- Information about the failure and/or reason for the return
- A copy of your dated proof of purchase

Record these details in [“Record of System Settings”](#) on page 61.

Return Material Procedure

If you are returning a product from the USA or Canada, follow this procedure:

1. Package the unit safely, preferably using the original box and packing materials. Please ensure that your product is shipped fully insured in the original packaging or equivalent. This warranty will not apply where the product is damaged due to improper packaging.
2. Include the following:
 - The RMA number supplied by Xantrex clearly marked on the outside of the box
 - A return address where the repaired unit can be shipped. Post office boxes are not acceptable.
 - A contact telephone number where you can be reached during work hours.
 - A brief description of the problem
3. Ship the unit prepaid to the address provided by your Xantrex Service Representative.

If you are returning a product from outside of the USA or Canada In addition to the above, you **MUST** include return freight funds and are fully responsible for all documents, duties, tariffs, and deposits.

If you are returning a product to a Xantrex Authorized Service Center (ASC) A Xantrex return material authorization (RMA) number is not required. However, you must contact the ASC prior to returning the product or presenting the unit to verify any return procedures that may apply to that particular facility.

Product Information

Serial number

Place of purchase

Date of purchase

Software Revision
Number (F15). (See
[page 34.](#))

Record of System Settings

Setting	Default	Your Setting or Recorded Data
Battery Volts (charged)	13.2	
Battery Amps (charged)	2%	
Battery Capacity	200Ah	
Power Share	Model dependent	
Idle Mode	4W	
CEF		
Number of CEF Recalculations		
Average depth of discharge		
Deepest depth of discharge		
Functions		
Auto Display Scanning (F01)	Off	
Display Sleep (F02)	On	
Ambient Battery Temperature (F03) Note: F03 depends on F16.	70° F (21.11° C)	
Ah / kilowatt hours (F04)	Ah	
Alternate Energy Mode (F05)	Off	
Manually set CEF (F06)	95%. This value should only be set if you don't want the Link 1000 to calculate CEF automatically.	

Record of System Settings

Setting	Default	Your Setting or Recorded Data
Temperature Coefficient (F07)	0.5	
Peukert Exponent (F08)	1.25	
Low Battery Discharge Floor (F09)	100%	
Battery Type (F10)	000 (liquid lead-acid)	
Second Battery Voltage Sense (F11)	Off	
Active Temperature Compensation (F16)	Off	

Index

Symbols

+I999 46

Numerics

0L, Error Code 50

20 hour rating 22, 42

-999 47

A

AC IN LED 6, 39

ACCEPT LED 6, 39

active temperature compensation 34

Ah

Ah LED described 36

displaying 36

over-charge 45

resetting 21

ambient temperature setting 24

Amps

Amps LED described 36

displaying 36

anti-corrosive spray 9

B

batteries

20 hour rating 22, 42

average discharge 47

charge efficiency 46

deepest discharge 47

equalizing 40

how to charge 40

how to equalize 41

number of CEF recalculations 46

over charging 45

overload 48

reading the state-of-charge 37

table of capacities 42

time remaining 36

when to charge 39, 40

battery capacity

determining 22

setting 23

testing 42, 43

battery history

average discharge 47

charging efficiency factor (CEF)
46

deepest discharge 47

number of CEF recalculations 46

reading 46

BATTERY STATUS light bar

how to read 37

illustrated 4, 25

battery temperature sensor 24, 34

battery temperature sensor, effect on settings 20
battery type setting 23, 33

C

cable clamp 9
CCC 36
CEF recalculation 46
CHARGE button LED 5
charged current percentage setting 25
charged parameters 25
CHARGER STATUS LEDs, described 39
Charging Efficiency Factor (CEF) 31, 46
CHG LED 6, 39
control panel
 electrical specifications 52
 illustrated 4
 mounting 13
 physical specifications 52
 testing 34

D

DATA LED 5
deepest discharge 47
default settings 53
display panel, testing 34
display units
 changing 36
 described 5
displaying
 Ah 36
 Amps 36
 Time remaining 36
 Volts 36

E

E99 46
electrical specifications, control panel 52
equalize charge 40
 gel cell batteries 42
 starting 41
 stopping manually 41
Error Codes
 0L 50
 E01 48
 E010 49
 E012 50
 E014 50
 E015 50
 E02 48
 E03 48
 E04 48
 E05 49
 E06 49
 E07 49
 E08 49
error codes, displayed 36, 48

F

F01 Auto Display Scanning 29
F02 Display Sleep 29
F03 Ambient Battery Temperature Setting 30
F04 Ah / kWhr Display 30
F05 Alternative Energy Mode 31
F06 Manually Set CEF 31
F07 Temperature Coefficient 31
F08 Peukert's Exponent 32
F09 Low Battery Discharge Floor 32
F10 Battery Type 33
F11 Second Battery Voltage Sense 33

- F12 Number of Overload Conditions 33
- F13 Number of Inverter Low Battery Shutdowns 33
- F14 Display Test 34
- F15 Display Software Revision Number 34
- F16 Active Temperature Compensation 34
- FLOAT LED 6, 39
- FUNC LED 5
- fuses
 - installing 17
 - type and number required 8

I

- I0 36
- i999 47
- idle mode setting, changing 28, 38
- installation
 - diagram 12
 - materials 8
 - overview 11
 - planning 8
 - reversed leads 18
 - safety 9
 - supplied parts 8
 - testing 17
 - tools 9
- INVERT button LED 5
- invert function, enabling 38
- inverter charger, disconnecting 18

L

- Link 1000
 - control panel illustrated 4
 - default settings 53
 - list of control functions 2

- list of monitoring functions 2
- serial number 60
- software revision number 34
- synchronizing to the battery 44
- testing the display 34
- LOCK LED 5
- Low battery discharge floor 32

M

- maintenance 18
- Mid-Capacity Rule 32, 39

N

- number of CEF recalculations 46

O

- over-charge Ah 45
- overload, battery 48

P

- phone cable
 - installing 17
 - removing 18
- physical specifications, control panel 52
- power consumption 52
- power share mode 42
- power share setting 27

R

- RESET LED 5
- resetting
 - Ah 21
 - all values 21

- returning products
 - how to package 60
 - policy 59
 - procedure 59
- reverse polarity 50

- S**
- second battery voltage sense 33
- serial number 60
- setup values
 - changing 20
 - default 53
 - locking 21
 - resetting Ah 21
 - resetting all 21
- shunt
 - high current 9
 - mounting and cabling 14
- shutdown
 - high battery voltage 48
 - low battery voltage 48
 - over temperature 48
- software revision number 34
- specifications
 - electrical 52
 - physical 52
- state-of-charge, how to read 37
- strain relief 9
- synchronizing Link 1000 to battery 44
- system overview diagram 12

T

- temperature sensor 20, 24, 34
- terminal block
 - illustrated 12
 - wiring 15
- time remaining
 - changing the setting 26

- displaying 36

V

- values
 - list of default values 53
 - resetting Ah 21
 - resetting all 21
- Volts, displaying 36

W

- warranty
 - terms and conditions 56
- wiring diagram 12